

# Vernier Height Gage

## SERIES 514 — Standard Height Gage with Adjustable Main Scale

### FEATURES

- Zero reference point can be adjusted.
- Stain chrome finished scales for glare-free reading.
- Extra-large base for rigidity.
- Optional magnifier for easier reading
- Carbide-tipped scriber is provided.



### SPECIFICATIONS

#### Metric

Range	Order No.	Accuracy	Graduation	Mass (kg)
0 - 300mm	<b>514-102</b>	±0.04mm	0.02mm	3.1
0 - 450mm	<b>514-104</b>	±0.05mm	0.02mm	3.4
0 - 600mm	<b>514-106</b>	±0.05mm	0.02mm	7.4
0 - 1000mm	<b>514-108</b>	±0.07mm	0.02mm	20.0
0 - 1500mm	<b>514-170</b>	±0.18mm	0.02mm	26.0

#### Inch/Metric — Inch model with inch/metric dual scale

Range	Order No.	Accuracy	Graduation	Mass (kg)
0 - 12" / 0 - 300mm	<b>514-103</b>	±.002"	.001" / 0.02mm	3.1
0 - 18" / 0 - 450mm	<b>514-105</b>	±.002"	.001" / 0.02mm	3.4
0 - 24" / 0 - 600mm	<b>514-107</b>	±.002"	.001" / 0.02mm	7.4
0 - 40" / 0 - 1000mm	<b>514-109</b>	±.003"	.001" / 0.02mm	20.0

### DIMENSIONS

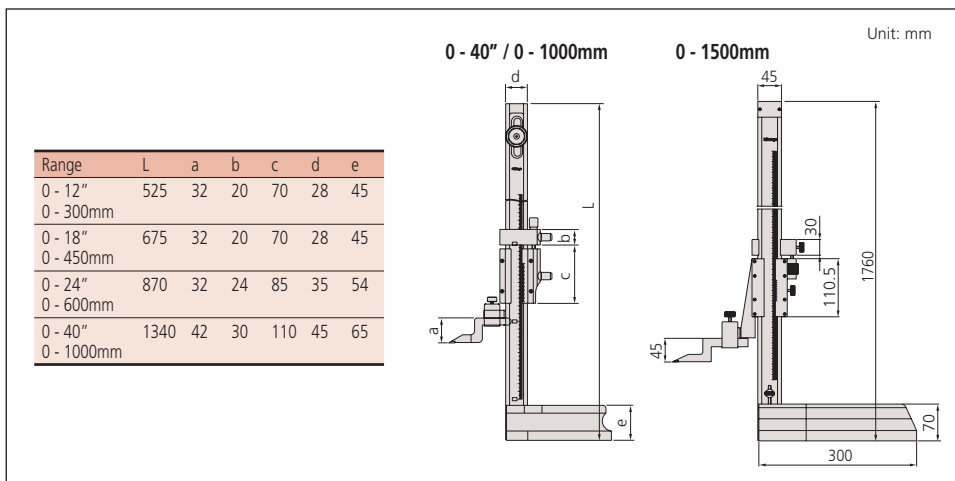

### Technical Data

Main scale adjustment: 15mm or 25mm  
Slider fine feed: 4mm, 6mm, 7mm or 20mm

### Standard Scriber Provided

Up to 600mm: Carbide-tipped scriber (**07GZA000**) and scriber clamp (**05GZA033**)  
0 - 1000mm: Carbide-tipped scriber (**905200**) and scriber clamp (**05GZA033**)  
0 - 1500mm: Carbide-tipped scriber (**900390**) and scriber clamp (**905008**)

### Dimension of scriber

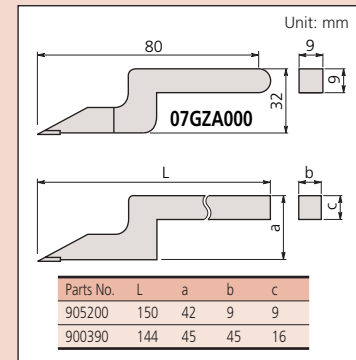

### Optional Accessories

**07GZA003**: Magnifier for 300, 450mm, 600mm models  
**07GZA015**: Magnifier for 1000mm and 1500mm models  
**953638**: Holding bar for test indicator (length: 50mm)  
**902053**: Swivel clamp used with holding bar

